

MCX SYSTEM HOST BOARDS WITH MULTI-CORE PROCESSORS

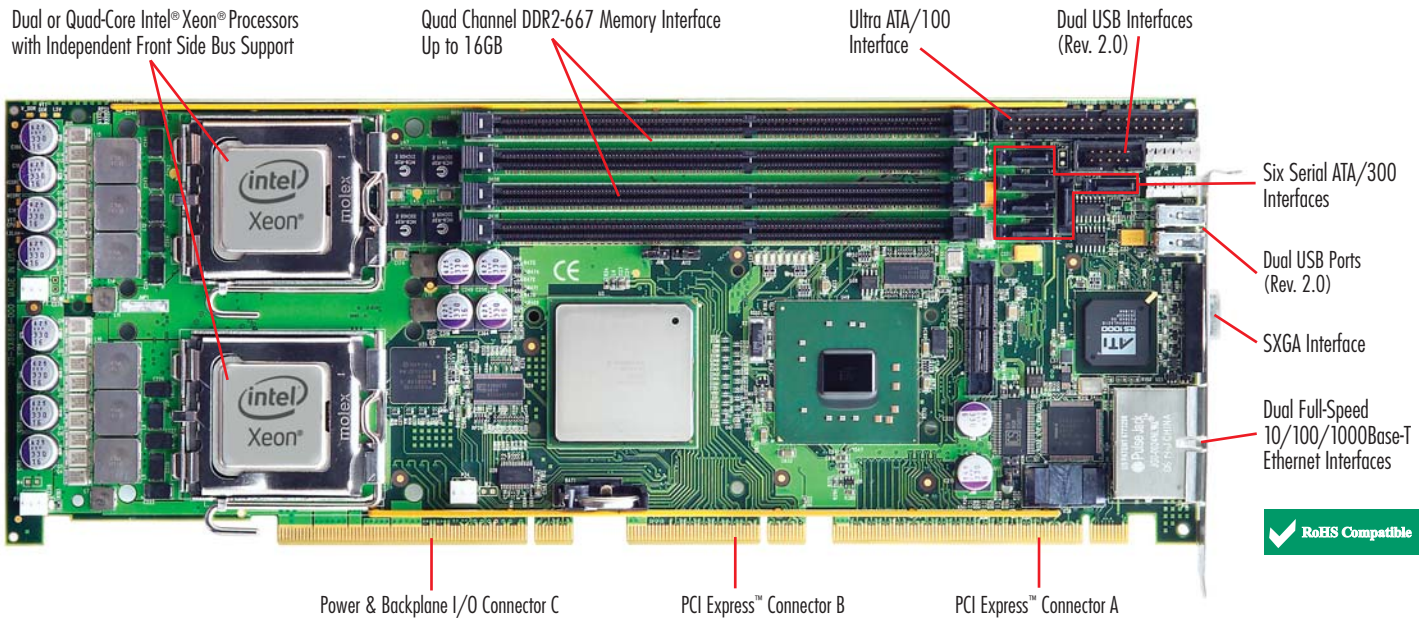

Trenton's MCX series of PICMG® 1.3 system host boards (SHBs) offers a wide variety of board configurations designed to excel in your most demanding and diverse server-class computing applications. Dual-Core processor options provide two and Quad-Core processors provide four execution cores per CPU. For dual-processor board configurations, each CPU has its own independent system bus to reduce data bottlenecks while maximizing processing throughput. The four-channel memory interface features DDR2-667 FB-DIMMS with a maximum of 16GB. An extended memory SHB configuration is available that supports up to 32GB of system memory.

PROCESSORS:

Dual-Core Intel® Xeon® Processors (5100 series), 1.6GHz - 3.0GHz*
 Quad-Core Intel® Xeon® Processors (5300 series), 1.66GHz - 2.66GHz*
 Quad-Core Intel® Xeon® Processors (5400 series), 2.0GHz - 3.0GHz*
 Processor Package: LGA771 (Socket J)

*Higher speeds as available

The chipset and the Intel® Xeon® processors on the MCX series support independent 1066MHz or 1333MHz system buses as well as the Intel® I/O Acceleration Technology (I/OAT). Intel® I/OAT improves system I/O performance with improved processor, MCH and ICH capabilities. Other processor features include:

- Dual-Core, 4MB Shared L2 Cache (5100 series)
- 32-bit and 64-bit computing via Intel® EM64T
- Demand-Based Switching with Enhanced Intel SpeedStep® Technology (EIST)
- Quad-Core: 2x4MB L2 Cache (5300 series), 2x6MB L2 Cache (5400 series)

CHIPSET:

Maximum MCXT and MCXE performance in dual processor applications is achieved with the independent system bus feature of the Intel® 5000P chipset. The chipset also enables 16GB (MCXT/MCXI) or 32GB (MCXE/MCXI-E) system memory SHB configurations. Other chipset features include configurable server-class PCIe link configurations, a four-channel DDR2 FB-DIMM interface and 1066/1333MHz system bus support.

PCI EXPRESS™ INTERFACES:

Trenton's server-class MCX series of SHBs provides two x8 and one x4 PCI Express links on a PICMG 1.3 server-class backplane. Each of the x8 links can be bifurcated into two x4 PCIe links, and the single x4 PCIe link can be divided into four x1 PCIe links. These links, along with eight PCIe reference clocks, are routed to SHB edge connectors A and B. Trenton's optional IOB31 module, part number 6474-000, may be used to provide an additional x4 PCIe link to the backplane. The PCI Express links support PCI Express option cards and bridge chips that provide PCI/PCI-X option card functionality. PCI Express auto-negotiation capability is supported on the MCX series of SHBs and enables communications to x1, x4, x8 and x16 PCI Express cards as well as PCI/PCI-X cards via PCI Express-to-PCI/PCI-X bridge chips on a PICMG 1.3 backplane.

DDR2-667/533 FB-DIMM MEMORY:

The DDR2-667/533 Fully-Buffered DIMM (FB-DIMM) interface is a four-channel interface originating at the Memory Controller hub with each channel terminating at an FB-DIMM module socket on the MCXT and MCXI SHBs. On the MCXT-E and MCXI-E SHBs, the four channels each terminate in two FB-DIMM sockets, for a total of eight FB-DIMMs. The SHBs use ECC registered PC2-5300 or PC2-4200 FB-DIMMs. The MCXT/MCXI SHBs support a maximum memory capacity of 16GB, while the MCXE/MCXI-E boards feature an extended memory capacity of 32GB. The peak memory interface bandwidth per channel is 8.0GB/s when using PC2-5300 FB-DIMMs. Detailed information on how the chipset's memory interface population rules affect memory interface bandwidth performance is posted on the MCX-series product detail web pages that can be found at www.TrentonTechnology.com.

SERIAL ATA/300 PORTS:

The integrated Serial ATA (SATA) controller provides six SATA ports with data transfer rates up to 300MB/s. Independent SATA drive operation and RAID 0, 1, 5 and 10 drive array configurations are supported on the MCX series of SHBs. SATA technology provides lower pin counts, reduced signaling voltages, simplified cabling, CRC error detection and hot-plug device support.

PCI EXPRESS™ CONFIGURATION AND BUS SPEEDS:

| | |
|------------------------------------------------|-----------------------------|
| PCI Express - Edge Connectors A & B | - Two x8 links, one x4 link |
| | - Eight reference clocks |
| PCI Express - (IOB31/PCIe Expansion) | - One x4 link |
| PCI Express - (on-board only) | - Three x4 links |
| PCI (on-board only) | - 32-bit/33MHz |
| Enterprise South Bridge Interface System or FS | - 2GB/s (x4 PCIe link) |
| | - 1066/1333MHz |

THREE ETHERNET INTERFACES - 10/100/1000BASE-T:

The MCX series of SHBs offers advanced Ethernet connectivity that supports two Gigabit Ethernet ports on the board's I/O bracket. RJ-45 connectors on the I/O bracket provide the mechanical interface to these Ethernet networks. A third Gigabit Ethernet interface is routed to edge connector C of the SHB for use on a PICMG 1.3 backplane.

UNIVERSAL SERIAL BUS INTERFACES (USB 2.0):

There are eight USB 2.0 interfaces on the MCX series of SHBs. USB ports 0 and 1 are located on the I/O bracket, on-board headers contain ports 2 and 3, and USB ports 4, 5, 6 and 7 are routed to the SHB's edge connector C for use on backplanes that support the optional PICMG 1.3 USB interface capability.

STANDARDS:

- PCI Express™ Base Specification 1.1
- SHB Express™ System Host Board PCI Express Specification - PCI Industrial Computer Manufacturers Group (PICMG®) 1.3



Dependable, always.

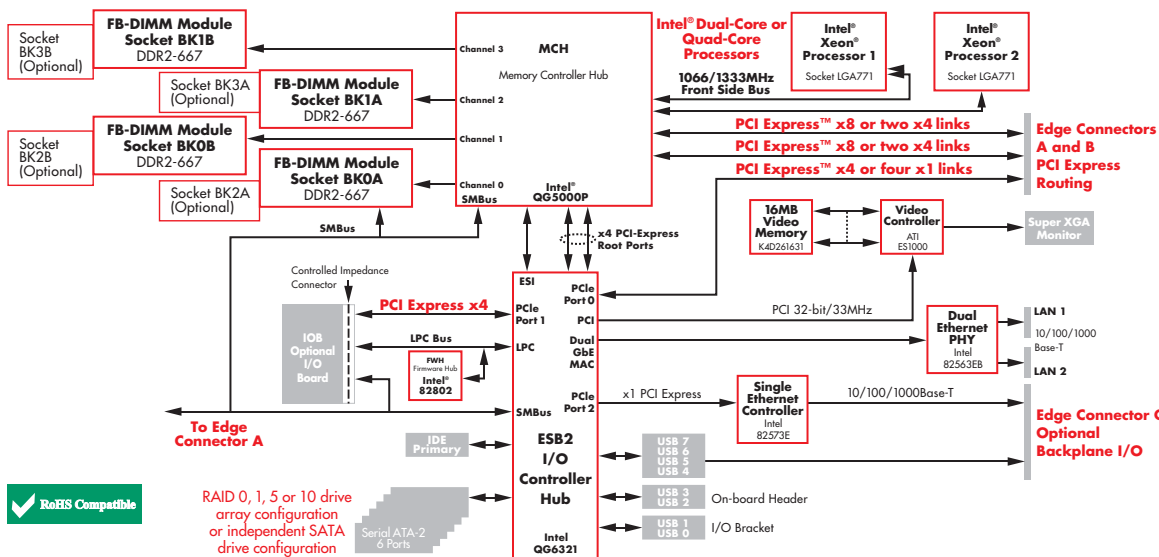

SUPER XGA INTERFACE:

Trenton MCX-series SHBs are equipped with the ATI® ES1000 video controller. The external memory chip used with the ES1000 provides 16MB of on-board video memory. The video controller supports pixel resolutions up to 1280 x 1024 (SXGA). Software drivers are available for popular operating systems.

BIOS (FLASH):

MCX-series boards use AMIBIOS8®, the flash BIOS resides in the SHB's Firmware Hub (FWH). AMIBIOS8 contains features such as:

- Support for flash devices for BIOS upgrading
- Integrated support for USB mass storage devices such as USB, CD-ROM, CD-RW, etc.
- Boot from network, USB mass storage devices, IDE or ATAPI
- Serial port console redirection to support headless operation (requires optional IOB30, part number 6391-000)
- SATA/ATA/ATAPI support includes 48-bit LBA addressing to support SATA/ATA/IDE hard drive capacities over 137GB

ADDITIONAL PRODUCT FEATURES:

I/O Features:

- Support for two EIDE Ultra ATA/100 disk drives
- Optional IOB30MC I/O plug-in expansion board includes:
 - Two high-speed serial ports
 - Enhanced bi-directional parallel interface
 - PS/2 mouse and keyboard interface (mini DIN connector)
 - Floppy drive interface
- Optional IOB31 I/O plug-in expansion board includes all IOB30MC functionality plus a x4 PCI Express link on the IOB31 edge connector. The edge connector plugs into a PCIe Expansion Slot on a PICMG 1.3 backplane.

AGENCY APPROVALS:

UL60950, CAN/CSA C22.2 No. 60950-00, EN55022:1998 Class B, EN61000-4-2:1995, EN61000-4-3:1997, EN61000-4-4:1995, EN61000-4-5:1995, EN61000-4-6:1996, EN61000-4-11:1994

APPLICATION CONSIDERATIONS:

Temperature/Environment:

- Operating Temperature: 0° to 40° C. (3.16GHz X5460 CPUs)
- Operating Temperature: 0° to 55° C. (L5408 and LV5138 CPUs)
- Operating Temperature: 0° to 45° C. (All other processors)
- Air Flow Requirement: 300LFM continuous airflow
- Storage Temperature: -40° to 70° C.
- Humidity: 5% to 90% non-condensing

APPLICATION CONSIDERATIONS (continued):

Power Requirements*:

Typical Values - CPU Idle State with 4GB of system memory

| CPU | Intel® No. | +5V | +12V | +3.3V |
|--------------|--------------------|-------|-------|-------|
| 2.83GHz | E5440 [†] | 1.75A | 5.75A | 3.00A |
| 2.0GHz | E5335 [†] | 1.75A | 7.50A | 3.00A |
| 2.33GHz | 5140 | 1.75A | 5.90A | 3.00A |
| 2.0GHz | 5130 | 1.75A | 5.80A | 3.00A |
| 2.33GHz (LV) | L5410 [†] | 2.00A | 6.01A | 3.38A |
| 2.13GHz (LV) | L5408 [†] | 2.00A | 5.80A | 3.04A |
| 2.13GHz (LV) | 5138 | 1.75A | 5.70A | 3.00A |

Typical Values - 100% CPU Stress State with 4GB of system memory

| CPU | Intel® No. | +5V | +12V | +3.3V |
|--------------|--------------------|-------|--------|-------|
| 2.83GHz | E5440 [†] | 2.00A | 14.75A | 3.20A |
| 2.0GHz | E5335 [†] | 2.00A | 15.60A | 3.20A |
| 2.33GHz | 5140 | 2.00A | 12.80A | 3.20A |
| 2.0GHz | 5130 | 2.00A | 12.70A | 3.20A |
| 2.33GHz (LV) | L5410 [†] | 2.05A | 12.41A | 3.55A |
| 2.13GHz (LV) | L5408 [†] | 2.11A | 9.80A | 3.08A |
| 2.13GHz (LV) | 5138 | 2.00A | 12.50A | 3.20A |

-12V @ < 100mA

Tolerance for all voltages is +/- 5%

Each 1GB of additional FB-DIMM system memory typically draws an additional 0.5A of +12V power

Some external USB devices may draw up to an additional 0.5A of 5V power per device

*Values stated are when using the MCXT-E system host board

[†]Quad-core processor

Mechanical:

The standard cooling solution used on the MCX series of SHBs enables placement of option cards approximately 2.77" (70.36mm) away from the top component side of the SHB. An optional low-profile cooling solution is available that allows the placement of option cards approximately 2.38" (60.45mm) away from the top component side of the SHB. Contact Trenton for temperature specification details when using the low-profile cooling solution.

The standard memory versions of the SHBs (MCXT and MCXI) have overall dimensions of 13.330" (33.858cm) L x 4.976" (12.639cm) H. The relative PICMG 1.3 SHB height off the backplane is the same as a PICMG 1.0 SBC due to the shorter PCI Express backplane connectors. The extended memory versions, models MCXT-E and MCXI-E, have overall dimensions of 13.330" (33.858cm) L x 5.726" (14.544cm) H.

ORDERING INFORMATION:

| Model # | CPU Speed | Intel® No. | Embedded CPU |
|-------------------------------------------------------------------|-----------|--------------------|--------------|
| Model Name: MCXT (Two Processors, Standard Memory Config.) | | | |
| 506633-811-xG | 2.83GHz | E5440 [†] | Yes |
| 506633-506-xG | 2.0GHz | E5335 [†] | Yes |
| 506633-108-xG | 2.33GHz | 5140 | Yes |
| 506633-106-xG | 2.0GHz | 5130 | Yes |
| 506633-908-xG | 2.33GHz | L5410 [†] | Yes |
| 506633-926-xG | 2.13GHz | L5408 [†] | Yes |
| 506633-206-xG | 2.13GHz | 5138 | Yes |
| Model Name: MCXI (One Processor, Standard Memory Config.) | | | |
| 506638-851-xG | 2.83GHz | E5440 [†] | Yes |
| 506638-546-xG | 2.0GHz | E5335 [†] | Yes |
| 506638-148-xG | 2.33GHz | 5140 | Yes |
| 506638-146-xG | 2.0GHz | 5130 | Yes |
| 506638-948-xG | 2.33GHz | L5410 [†] | Yes |
| 506638-966-xG | 2.13GHz | L5408 [†] | Yes |
| 506638-246-xG | 2.13GHz | 5138 | Yes |
| Model Name: MCXT-E (Two Processors, Ext. Memory Config.) | | | |
| 506685-811-xG | 2.83GHz | E5440 [†] | Yes |
| 506685-506-xG | 2.0GHz | E5335 [†] | Yes |
| 506685-108-xG | 2.33GHz | 5140 | Yes |
| 506685-106-xG | 2.0GHz | 5130 | Yes |
| 506685-908-xG | 2.33GHz | L5410 [†] | Yes |
| 506685-926-xG | 2.13GHz | L5408 [†] | Yes |
| 506685-206-xG | 2.13GHz | 5138 | Yes |
| Model Name: MCXI-E (One Processor, Ext. Memory Config.) | | | |
| 506700-851-xG | 2.83GHz | E5440 [†] | Yes |
| 506700-546-xG | 2.0GHz | E5335 [†] | Yes |
| 506700-148-xG | 2.33GHz | 5140 | Yes |
| 506700-146-xG | 2.0GHz | 5130 | Yes |
| 506700-948-xG | 2.33GHz | L5410 [†] | Yes |
| 506700-966-xG | 2.13GHz | L5408 [†] | Yes |
| 506700-246-xG | 2.13GHz | 5138 | Yes |

(xG = Memory)

The stated bus speed, memory and communication interface speeds are component maximums; actual system performance may vary.

Intel, Intel I/OAT, Intel EIST, Intel EM64T and Intel Xeon are trademarks or registered trademarks of Intel Corporation. All other product names are trademarks of their respective owners.

Copyright © 2008 by TRENTON Technology Inc. All rights reserved



Dependable, always.