

W24L100-MLA2FP

23.8" PCAP Rack Mount Defence Display



KEY FEATURES

- 23.8", 1920 x 1080 resolution
- Compliant MIL-STD 810G/ MIL-STD 461E
- Rack mount mechanical design, supports VESA mount
- PCAP multi-touch screen
- Defence-grade power connector (MIL-DTL-38999/1)
- AC 100~240V, Universal, $\pm 10\%$; DC 9~36V, $\pm 10\%$ (Optional)
- Convenient on-screen display controls



SPECIFICATIONS

Display	
Resolution	1920x1080
Contrast Ratio	3000:1
Display Color	16.7M Colors
Active Area	527.04x296.46 mm
Size	23.8 inches
Panel Brightness	250.0 nits
View Angles	89,89,89,89
Touch / Glass	Projected Capacitive Multi Touch Screen PCAP with With ITO Flim (Optional)
Environment	
Operating Humidity	10% to 95% RH
Storage Temperature	-10°C~60°C
Operating Temperature	0~50°C
Compliance	
MIL-STD 461E/F/G	RE101 / RE102 CE101 / CE102 CS118 with EMI Glass / Touch(Optional) RS101 / RS 103 CS101 / CS 106 / CS 109 / CS 114 / CS 115 / CS 116
MIL-STD 810G/H	Vibration Method 514.6 Humidity Method 507.5 Transit Drop Method516.6
Certification	
Certification	CE, FCC
IO Ports	
USB Port	1 x USB for Touch Screen
Video	1 x VGA 5 x BNC (R,G,B,H,V) 1 x DVI-D
Mechanical	
Dimension	635.2 x 430.9 x 66 mm
Enclosure	Metal Housing with Aluminum Bezel
Mounting	Rack Mount/ VESA Mount
Cooling System	Fanless Design
Accessory	
Accessory	1 x User Manual(Hardcopy) 1 x Power Cord MIL-DTL-38999/1 1 x VGA Cable 1 x DVI Cable 1 x VGA to 5 BNC Shielding Cable

Power	
Power Rating	AC 100~240V, Universal, ±10% DC 9~36V, ±10% (Optional)
Control	
Button	7 key: Power Decrease Increase Exit/ Auto Menu Day/ Night Lock/ Unlock

DIMENSIONS UNIT:MM

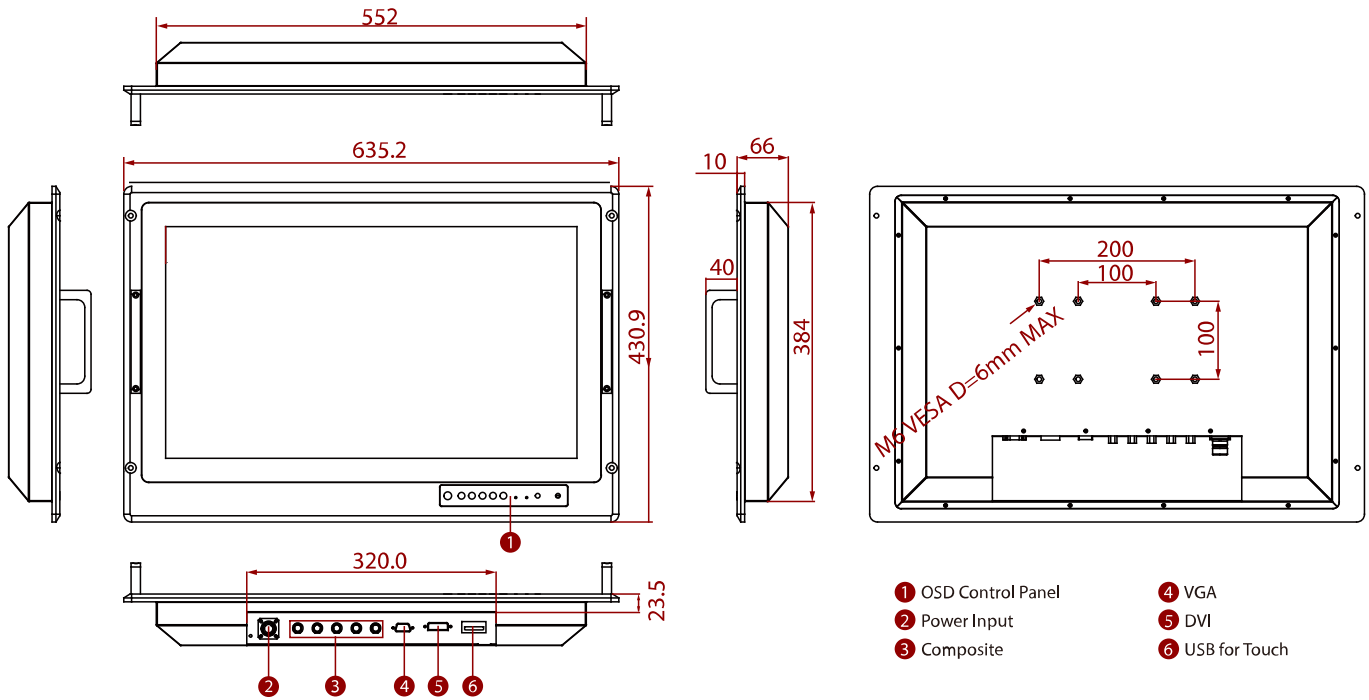

NOTE

1. This is a simplified drawing and some components are not marked in detail.
2. If you require an external test report, Winmate will charge an NRE fee.
3. Please contact our sales representative if you need further product information.
4. All specifications are subject to change without prior notice.
5. The product shown in this datasheet is a standard model. For diagrams that contain customized or optional I/O, please contact the Winmate Sales Team for more information.