

HF (13.56 MHz)
 BIS M-101-01/L
 Order Code: BIS003Y

BALLUFF

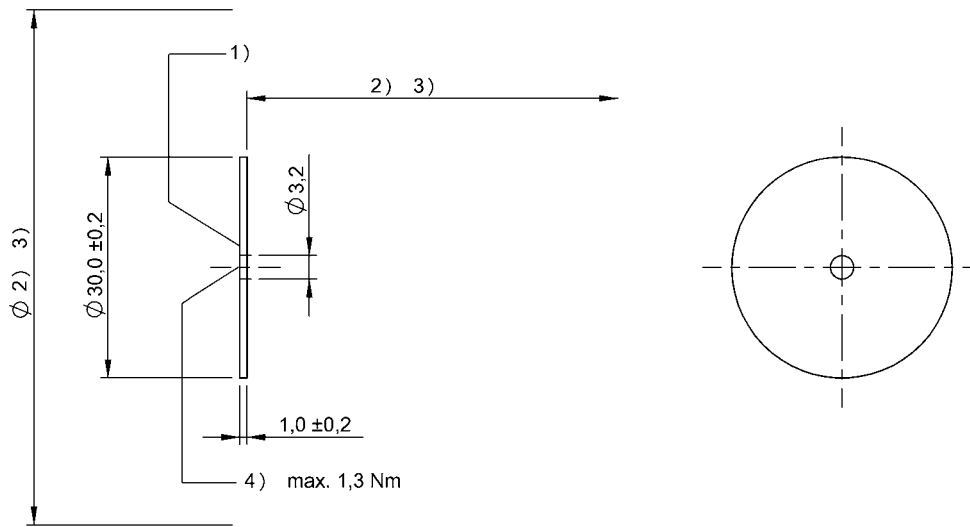

- 1) Sensing surface
- 2) Clear zone
- 3) see corresponding R/W head
- 4) Tightening torque



Basic features

Antenna type	round
Approval/Conformity	CE WEEE EAC
EN 55011	Size 1, Cl. A
EN 55022	Size 1, Cl. B
Principle of operation	Data carrier

Electrical data

Data retention time/years	≥ 10
Memory organization	47 × 16 bytes
Programming cycles	≥ 100.000
Programming time	for 16 bytes: 0.040s
Read cycles	Unlimited
Read time	for 16 bytes: 0.02 s User ID for 4 bytes: 0.02s

Environmental conditions

Ambient temperature	-25...70 °C
Continuous shock load	yes
EN 60068-2-27, Shock	yes
EN 60068-2-32 Free fall	yes
EN 60068-2-6, Vibration	yes
IP rating	IP67, 1 m, 30 min
Storage temperature	-25...85 °C

Functional Characteristics

Memory type	EEPROM
Supported data carrier types	DIN ISO 14443
UID serial number, read-only	4 Byte
User data, read/write	752 Byte

Material

Housing material	Epoxy-resin/fiberglass, GF
------------------	----------------------------

Mechanical data

Application weight	1.60 g
Dimension	Ø 30 x 1 mm
Installation	metal-free (clear zone)

HF (13.56 MHz)
BIS M-101-01/L
Order Code: BIS003Y

BALLUFF

Remarks

Values are under rated conditions unless otherwise specified.

Only when used together with the appropriate read/write head.

For installation requirements see corresponding read/write head.

Time specification includes data check.

Torsional, bending and impact loading is not permitted.

a) Hygroscopicity The hygroscopicity of the cured material depends heavily on the ambient temperature. Saturation in water at +20 °C / 6 days = 0.3 %

Saturation in water at +70 °C / 3 days = 3.0 %

For installation in metal: Observe clear zone.

Recommended screw: M3, 8.8