

W24IAD3S-SPA269-P1

23.8" Intel® Core™ i5-1235U IP69K Stainless P Series Panel PC



KEY FEATURES

- 12th Generation Intel® Core™ i5-1235U 3.3GHz(up to 4.40 GHz)
- Fanless cooling system
- SUS316 / AISI 316 stainless steel for food and chemical industries
- Full IP69K waterproof enclosure
- A true flat, easy-to-clean front surface with edge-to-edge design
- Waterproof sealed conduit pipe for cable protection
- Support VESA mount, and optional Yoke mount stand
- Support Glove/ Rain mode
- Optical bonding (optional)



OVERVIEW

HEALTH AND HYGIENE

For Strict Hygiene Requirements

With stainless steel housing and IP69K protection for dust and water resistance, this Panel PC is ready for high-pressure, high-temperature washdowns regularly. The Panel PCs are designed for industries that require stringent disinfection processes and splashing cleanup routines found in Food, Beverage, and Chemical applications.

DURABILITY WITH CONDUIT PIPE

Extra Protection with Conduit Pipe

Never worry about exposed cables again. The custom-built waterproof conduit pipe is pre-installed to give an additional layer of protection for any peripheral cables connected to the device. The protection grants increased product longevity to reduce downtime in the production facilities.

PCAP TOUCH

Projected Capacitive Touchscreen

The highly-sensitive touch screen and PCAP multi-touch support make it easy for users to key in data, rotate images, drag and drop files, and zoom in with two or more fingers.

SPECIFICATIONS

Display			
Resolution	1920x1080	Size	23.8 inches
Contrast Ratio	3000:1	Panel Brightness	250.0 nits
View Angles	89,89,89,89	Active Area	527.04x296.46 mm
Touch / Glass	Projected Capacitive Multi Touch Screen		
System Specification			
WLAN	Support (Optional)	BT	Support (Optional)
Processor	Intel® Core™ i5-1235U 3.3GHz(up to 4.40 GHz)	Memory	1 x SO-DIMM, DDR5 4800 MHz, 8GB 16GB (Optional) 32GB (Optional)
Storage	1 x M.2 2280 M-Key NVMe SSD 256GB 512GB (Optional) 1TB (Optional) 2TB (Optional) 1 x SATA III for 2.5" SSD/HDD up to 2TB (Optional)	Ethernet controller	2 x Intel® Ethernet Controller
Security	TPM 2.0	Operating System	Windows 11 IoT Enterprise (64 bit) (Optional) Windows 11 Pro 64 bit (Optional) Linux Ubuntu 22.04(Do not support Wake on Touch) (Optional)
Mechanical			
Dimension	620 x 390 x 56 mm	Weight	10Kg

Mounting	VESA mount Yoke mount (Optional)	Enclosure	Stainless Housing
Cooling System	Fanless Design		
Environment			
Operating Humidity	10% to 90% RH, Non-Condensing	Operating Temperature	0°C to 45°C
Storage Temperature	-20°C to 60°C	IP rating	IP69K
Certification			
Certification	CE, FCC		
IO Ports			
USB Port	2 x USB3.2 Gen1x1 (Type-A)	Serial Port	1 x RS232/422/485 (Default RS232)
Video	1 x HDMI 1.4	LAN	2 x Giga LAN RJ45 Connector
Indicator	1 x LED Indicator on power button		
Control			
Button	1 x Power Button		
Accessory			
Accessory	1 x Waterproof Conduit 1.5m 1 x Waterproof Conduit 0.3m 2 x Elbow for connect the conduit 1 x AC to DC power adapter with power cord 1 x D-sub9(male) to RJ45 adapter 1 x D-sub9(female) to RJ45 adapter 1 x External RJ45 male to male cable VESA screws	Optional Accessory	1 x Open wire cable for phoenix connector (Optional) Yoke mount stand kit (Optional)
Power			
Power Rating	12V DC		

DIMENSIONS UNIT:MM

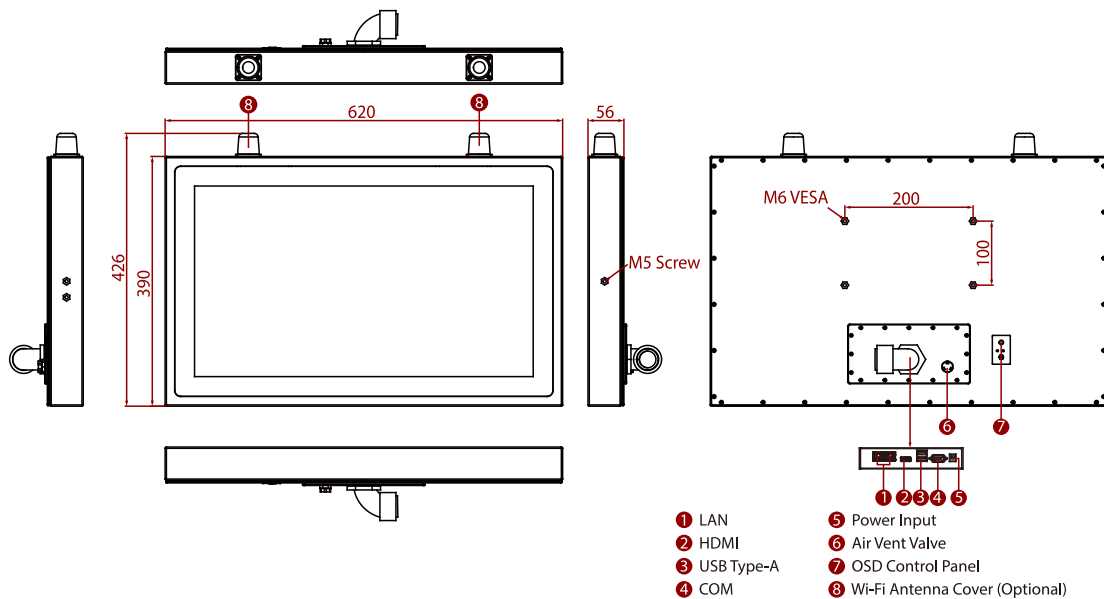

NOTE

1. This is a simplified drawing and some components are not marked in detail.
2. Please contact our sales representative if you need further product information.
3. All specifications are subject to change without prior notice.
4. The product shown in this datasheet is a standard model. For diagrams that contain customized or optional I/O, please contact the Winmate Sales Team for more information.