

FM08E

8inch Windows Vehicle Mounted Computer with Intel® Elkhart lake x6413E



KEY FEATURES

- Intel® Elkhart lake x6413E Processor
- 8" 1280 x 800 Panel with PCAP touch screen mobile computer mounts
- Field replaceable front panel to reduce service costs
- IP65 waterproof and dustproof
- Wide range operating temperature

INTRODUCTION

Winmate FM Series Windows Vehicle Mounted Computer (VMC) is engineered for industrial reliability and versatility, offering sizes from 8" to 12" and powered by the Intel® Elkhart Lake x6413E processor. Built for tough environments, it features an IP65-rated waterproof and dustproof design, wide operating temperature range, and a field-replaceable front panel for reduced service costs. Optional QWERTY keypad and PCAP touch screen provide enhanced usability, making it ideal for logistics, fleet management, and demanding industrial applications.

SPECIFICATIONS

Display

Resolution	1280x800	Size	8.0 inches
Contrast Ratio	1500:1	Panel Brightness	800.0 nits
View Angles	80,80,80,80	Type	Projected Capacitive Multi Touch
Touch Mode	Support Hand / Gloves and Rain Mode		

System Specification

Processor	Intel Atom x6413E 1.5GHz (up to 3GHz) Intel Atom x6425E 2GHz (up to 3GHz) (Optional) Intel Atom x7433RE 1.5 GHz (up to 3.4 GHz) (Optional) Intel Atom x7835RE 1.3 GHz (up to 3.6 GHz) (Optional)	Memory	1 x SO-DIMM, DDR4 3200 MHz, 4GB 8GB (Optional) 16GB (Optional)
Storage	1 x M.2 2242 SSD 128GB 256GB (Optional) 512GB (Optional)	Security	TPM 2.0
Operating System	Windows 10 IoT Enterprise LTSC (64 bit) Windows 11 IoT Enterprise LTSC (64 bit) (Optional)	WLAN	Support
BT	Support	WWAN	4G/LTE (Optional)
GNSS	GPS/AGPS	Sensors	G-Sensor, Light Sensor ,Temp Sensor

Camera

Front Camera	2MP Camera
---------------------	------------

Environment

Operating Humidity	5% to 95% RH, Non-Condensing	Operating Temperature	-30°C to 60°C
Storage Temperature	-30°C to 60°C	Shock	MIL-STD-810H Method 516.8 Procedure I
Vibration	MIL-STD-810H Method 514.8 Procedure I	IP rating	IP65
Impact	Support EN62262 IK07 Rating	ESD	Compliant with EN 61000-4-2, enhanced ESD to ±8kV direct & ±12kV

Control

Button	QWERTY keyboard, 1 x Power Button, 10 x Function Button (Programmable Function Key Configured by Winset)
---------------	---

IO Ports

USB Port	1 x USB Type-C(Tablet) 1 x DB9 Connector for 2 x USB 2.0 Port(Docking)	Serial Port	2 x COM Port(Docking)
SD Card Slot	1 x Micro SD Card Slot(Tablet)	SIM Card Slot	1 x Dual-Nano SIM Card Slot
Audio	2 x Speaker(Docking) 1 x CANBus or 1 x Audio(Docking)	LAN	1 x Gigabit LAN port(Docking)
Indicator	6 x LED Indicator (WLAN, BT, UPS battery, HDD, Screen Blanking, Heater)	Docking Connector	SMA Connector(female) for external antenna WLAN SMA Connector(female) for external antenna GPS (Optional) SMA Connector(female) for external antenna WWAN (Optional)

Mechanical

Dimension	Tablet: 268 x 214 x 32 mm (10.6 x 8.42 x 1.26 inches) Docking: 202 x 245 x 52 mm (7.9 x 9.6 x 2.04 inches)	Weight	Tablet 1.7 kg (3.75 lbs) Docking 1.6 kg (3.53 lbs)
Mounting	RAM mount/ VESA mount	Cooling System	Fanless Design
Docking Housing	Aluminum Alloy Housing		

Security Function

SOTI MobiControl	SOTI MobiControl Compliance
-------------------------	-----------------------------

Accessory

Accessory	5M Power Cable with Fuse Kit 0.3M USB Cable 0.15M Power Converter Cable DC Jack Power Cable 84W Adapter with power cable Cable Clamp Kit Wi-Fi Antenna x 2 Quick Start Guide External Antenna Fixing Bracket Dock + Latch Locking Key Stylus Kit + Screw	Optional Accessory	1.8M RS232 Cable 0.3M Audio Cable 1.8M CAN BUS Cable 1.8M CAN BUS Open Wire Cable 2M IP65 LAN Cable GPS & LTE 2M Combo Antenna(VM240) GPS & LTE 5M Combo Antenna (VM9C) Magnetic Combo Antenna (VM10S) WWAN Antenna
------------------	--	---------------------------	---

Power

Battery	7.6V UPS Battery (2S1P) Minimum 30 minutes	Power Rating	Docking: 10V-60V with ignition control Tablet: 12V DC In
Consumption	45W (Typical)		

DIMENSIONS UNIT:MM

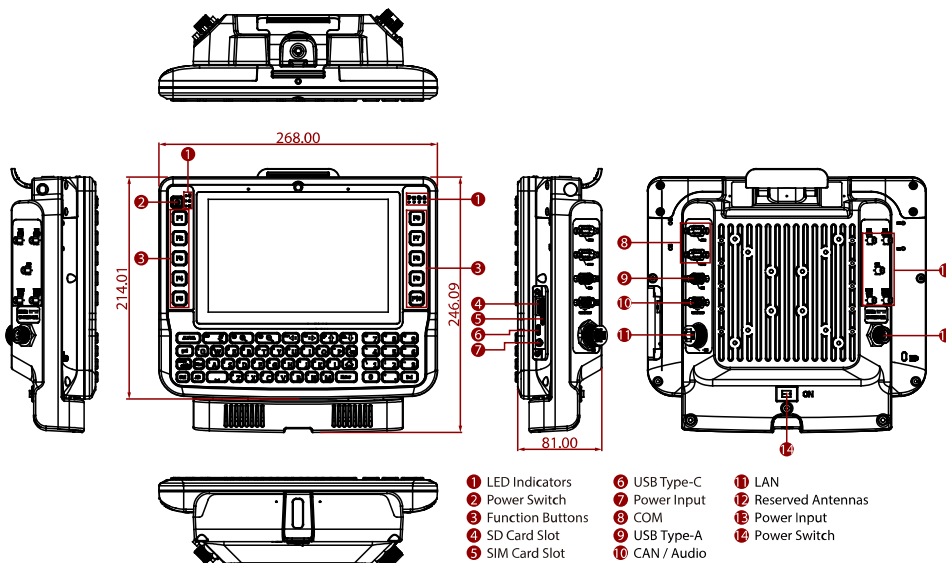

NOTE

- Total usable memory will be less dependent upon actual system configuration.
- SOTI is available upon request.
- Length measurements do not include protrusions. Weight varies with options.
- Measured at dimming LCD brightness. Varies depending on the usage conditions, or when an external device is attached.
- Accessories may vary depending on your configuration.
- This is a simplified drawing and some components are not marked in detail.
- The product shown in this datasheet is a standard model. For diagrams that contain customized or optional I/O, please contact the Winmate Sales Team for more information.
- COM port can supply 5V power via the 9th pin.