

FM12MG

12.1" Android Vehicle Mounted Computer with Genio 510 A78 + A55 CPU



KEY FEATURES

- ARM Genio 510 2 x A78 2.0GHz + 4 x A55 2.0GHz CPU
- 12.1" 1024 x 768 Panel with PCAP touchscreen
- Field replaceable front panel to reduce service costs
- IP65 waterproof and dustproof
- Wide range -30°C to 50°C operating temperature

INTRODUCTION

Winmate FM Series Android Vehicle Mounted Computer (VMC) is a rugged and versatile solution designed for demanding industrial and logistics applications. Powered by ARM Genio 510 and Qualcomm® Snapdragon™ 660 processors, it delivers reliable performance for forklift and fleet operations. Featuring an IP65-rated waterproof and dustproof design, a wide -30°C to 50°C operating temperature range, and a field-replaceable front panel to reduce service costs, the FM Series ensures durability and efficiency. Its built-in backup battery enables seamless dock-to-dock transitions, ensuring uninterrupted productivity.

SPECIFICATIONS

Display

Type	Projected Capacitive Multi Touch	Touch Mode	Support Hand, Stylus, Glove Mode
Resolution	1024x768	Size	12.1 inches
Contrast Ratio	1000:1	Panel Brightness	400 nits 800 nits(Optional)
View Angles	89,89,89,89		

System Specification

Processor	ARM Genio 510 2 x A78 2.0GHz + 4 x A55 2.0GHz	Memory	4GB LPDDR4
Storage	Onboard 64 GB	Operating System	Android 13 Linux Yocto 5.10.104 with QT 5.15 (Optional) Linux Ubuntu 22.04 (Optional)
WLAN	Support with Internal Antenna Either one with External Antenna (Optional)	BT	Support
WWAN	4G/LTE with External Antenna (Optional)	GNSS	GPS/GLONASS with External Antenna (Optional)
Sensors	G-Sensor, Temp. Sensor		

Camera

Front Camera	2MP Camera
--------------	------------

Mechanical

Dimension	Tablet: 307 x 225 x 41 mm Docking: 202 x 245 x 52 mm	Weight	2.5 kg
Mounting	RAM mount/ VESA mount	Cooling System	Fanless Design

IO Ports

USB Port	1 x USB 2.0 Type C (OTG)(Tablet) 1 x DB9 Connector for 2 x USB 2.0 Port(Docking)	Serial Port	2 x COM Port(Docking)
SD Card Slot	1 x Micro SD Card Slot(Tablet)	SIM Card Slot	1 x Dual-Nano SIM Card Slot(Tablet)
Audio	2 x Speaker(Docking) 1 x CANBus or 1 x Audio(Docking)	LAN	1 x Gigabit LAN port(Docking)
Indicator	3 x LED Indicator (WLAN, UPS battery, Heater)	Docking Connector	SMA Connector(female) for external antenna WLAN SMA Connector(female) for external antenna GPS (Optional) SMA Connector(female) for external antenna WWAN (Optional)

Environment

Operating Humidity	5% to 95% RH, Non-Condensing	Operating Temperature	-30°C to 60°C
Storage Temperature	-30°C to 60°C	Shock	MIL-STD-810H Method 516.8 Procedure I
Vibration	MIL-STD-810H Method 514.8 Procedure I	IP rating	IP65
Impact	Support EN62262 IK07 Rating	ESD	Compliant with EN 61000-4-2, Enhanced ESD to ±8kV Direct & ±12kV Air

Certification

Certification	CE, FCC
----------------------	---------

Control

Button	1 x Power Button, 5 x Function Button (Programmable Function Key Configured by Winset)
---------------	---

Power

Battery	7.6V UPS Battery (2S1P) Minimum 30 minutes	Power Rating	Docking: 10V-60V with ignition control Tablet: 12V DC In
----------------	---	---------------------	---

Security Function

SOTI MobiControl	SOTI MobiControl Compliance
-------------------------	-----------------------------

Accessory

Accessory	5M Power Cable with Fuse Kit 0.3M USB Cable 0.15M Power Converter Cable DC Jack Power Cable 84W Adapter with power cable Cable Clamp Kit Wi-Fi Antenna x 2 Quick Start Guide External Antenna Fixing Bracket Dock + Latch Locking Key Stylus Kit + Screw	Optional Accessory	1.8M RS232 Cable 0.3M Audio Cable 1.8M CAN BUS Cable 1.8M CAN BUS Open Wire Cable 2M IP65 LAN Cable GPS & LTE 2M Combo Antenna(VM240) GPS & LTE 5M Combo Antenna (VM9C) Magnetic Combo Antenna (VM10S) WWAN Antenna USB-C to HDMI Adapter
------------------	--	---------------------------	--

DIMENSIONS UNIT:MM

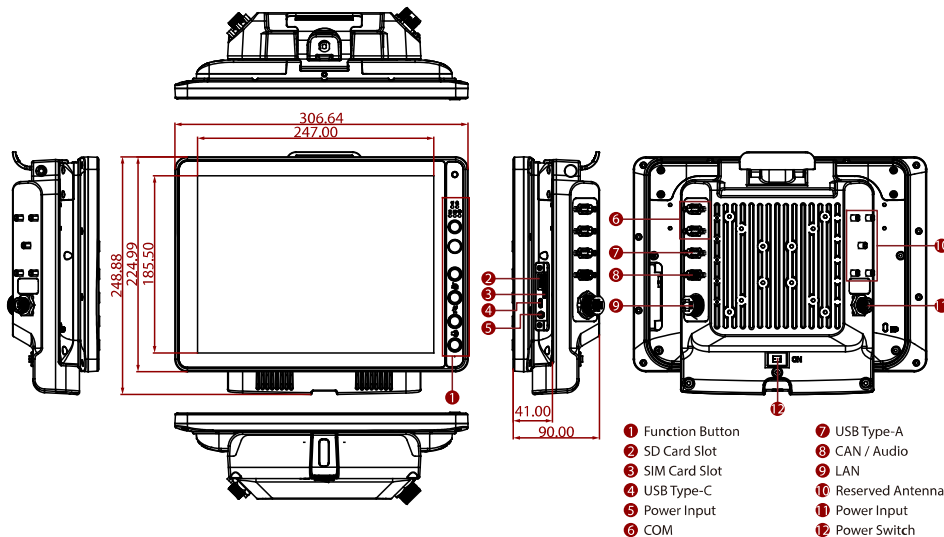

NOTE

- Total usable memory will be less dependent upon actual system configuration.
- CANBus and audio are mutually exclusive.
- The heater is a customized feature available by request.
- SOTI is available upon request.
- Length measurements do not include protrusions. Weight varies with options.
- Measured at dimming LCD brightness. Varies depending on the usage conditions, or when an external device is attached.
- Accessories may vary depending on your configuration.
- Two Wi-Fi antennas are included in the standard package.
- The product shown in this datasheet is a standard model. For diagrams that contain customized or optional I/O, please contact the Winmate Sales Team for more information.
- Please order one bracket for one antenna. For example, if you plan to use two antennas, please order two brackets.
- Notice that only one antenna is included in the package. If you plan to use the WWAN function please order two WWAN antennas.
- This is a simplified drawing and some components are not marked in detail.
- COM port can supply 5V power via the 9th pin.