

# M116AD

## 11.6" Windows Rugged Tablet PC with Intel® Core™ i5-1235U



### KEY FEATURES

- 11.6" 1920 x 1080, 850 nits IPS LED Panel with direct optical bonding
- Intel® Core™ i5-1235U Alder Lake processor
- IP65 waterproof and dustproof, MIL-STD-810H shock, vibration and drop resistance
- Sunlight readable with antiglare solution
- Hotswappable battery design
- USB TypeC port support power delivery 20V In



### OVERVIEW

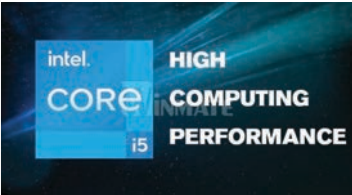

#### High Computing Performance

Powered by Intel's Alder Lake processor, Winmate's M116AD series offers high performance with minimal power consumption, addressing the needs of the most demanding professional-grade applications.



#### Sunlight Readable Display with Anti-Glare Solution

Wimate's M116AD series provides an exceptional viewing experience, whether used indoors or outdoors. This is attributed to its vibrant 11.6" size, 1920 x 1080 resolution, optical bonding technology, and anti-glare touch treatment.



#### Enhancing Efficiency with Hot-Swappability

Wimate's M116AD series features a hot-swappable battery design, allowing users to exchange batteries seamlessly without powering down the device. This ensures uninterrupted operation, eliminating downtime for enhanced productivity.



#### Real-time Connectivity through PCAP Touchscreen

Wimate's M116AD series provides an exceptional user touch experience with Projected Capacitive (P-CAP) Multi-Touch technology. It supports various modes, including Rain, Glove, and Stylus modes. Besides the P-CAP Technology, Winmate's M116AD features WWAN, WLAN, GPS, and BT connectivity options, allowing users to connect according to their preferences.

Additionally, the M116AD features a 2MP front camera and an 8MP rear camera, with the option to equip it with a 1D/2D Barcode Reader or HF RFID Reader for added functionality.



#### Designed for Durability and Mobility

Wimate's M116AD series is crafted to endure various temperatures, drops, shocks, and vibrations. Specifically designed for industrial-grade applications, Winmate's M116AD series has successfully met the MIL-STD-810H, MIL-STD-461G standards and IP65 rating, ensuring resilience against outdoor challenges.

### SPECIFICATIONS

<b>Display</b>			
<b>Bonding</b>	Optical Bonding for Sunlight Viewability	<b>Resolution</b>	1920x1080
<b>Size</b>	11.6 inches	<b>Contrast Ratio</b>	1000:1

<b>Panel Brightness</b>	850.0 nits	<b>View Angles</b>	85,85,85,85
<b>Type</b>	Projected Capacitive Multi Touch	<b>Viewability</b>	Anti-Glare touch treatment
<b>Touch Mode</b>	Support Hand/Rain, Stylus, Glove Mode		
<b>System Specification</b>			
<b>Processor</b>	Intel Core i5-1235U (up to 4.4GHz)	<b>Memory</b>	8GB DDR5 SDRAM 16GB DDR5 SDRAM (Optional) 32GB DDR5 SDRAM (Optional)
<b>Storage</b>	256GB M.2 NVMe SSD Additional storage available with micro SDXC card slot (Optional) 512GB M.2 NVMe SSD (Optional) 1TB M.2 NVMe SSD (Optional) 2TB M.2 NVMe SSD (Optional)	<b>Security</b>	Trusted Platform Module (TPM) 2.0 Kensington Lock
<b>Operating System</b>	Windows 10 IoT Enterprise LTSC (64 bit) Windows 11 IoT Enterprise LTSC (64 bit) (Optional)	<b>WLAN</b>	Support
<b>BT</b>	Support	<b>WWAN</b>	4G LTE (Optional) 5G (Optional)
<b>GNSS</b>	GPS, GLONASS	<b>RFID</b>	HF RFID reader 13.56 MHz (Optional)
<b>Sensors</b>	Light sensor/ G-sensor / Gyro		
<b>Camera</b>			
<b>Front Camera</b>	2MP Front Camera	<b>Rear Camera</b>	8MP Rear Camera with auto-focus and LED light
<b>Mechanical</b>			
<b>Dimension</b>	300.67 x 201.97 x 22.5 mm	<b>Weight</b>	1.4 kg (3.1 lbs) with standard battery
<b>Cooling System</b>	Fan Design		
<b>IO Ports</b>			
<b>USB Port</b>	1 x USB 3.0 (Type A), 1 x USB 3.0 (Type-C support Power Delivery 20V In)	<b>SD Card Slot</b>	1 x Micro SDXC slot
<b>SIM Card Slot</b>	1 x Micro SIM card slot	<b>Video</b>	1 x Micro HDMI (Optional)
<b>Audio</b>	1 x Audio combo 3.5mm audio combo jack Dual Digital Mic With Noise Cancellation	<b>LAN</b>	1 x RJ45-10/100/1000 GigaLAN port (Optional)
<b>Indicator</b>	4x LED Indicator for Power, Battery, HDD, RF status	<b>Docking Connector</b>	1 x 19-pin docking connector
<b>Environment</b>			
<b>Operating Humidity</b>	10% to 90% RH, non-condensing	<b>Operating Temperature</b>	-20°C to 60°C
<b>Storage Temperature</b>	-30°C to 70°C (-22°F to 158°F)	<b>Shock</b>	MIL-STD-810H Method 516.8 Procedure I
<b>Vibration</b>	MIL-STD-810H Method 514.8 Procedure I	<b>IP rating</b>	IP65
<b>Drop</b>	MIL-STD-810H Method 516.8, 4 ft	<b>EMC</b>	MIL-STD-461G CE101, CE102, RE101, RE102, CS118 (Default) MIL-STD-461G CS101, CS114, CS115, CS116, RS101, RS103 (Optional)
<b>Certification</b>			
<b>Certification</b>	CE, FCC		
<b>Security Function</b>			
<b>SOTI MobiControl</b>	SOTI MobiControl Compliance	<b>Kensington Lock</b>	Kensington Lock Support
<b>Control</b>			
<b>Button</b>	1 x Power, 3 x function keys		
<b>Power</b>			
<b>Battery</b>	Hot-swappable 11.55V, typ. 4558 mAh Li-Polymer Battery (3S2P) Optional 15.4V, typ. 5900 mAh Li-Polymer Battery (4S1P)	<b>Battery Operating Time</b>	Standard. Battery: 8 hours
<b>Power Rating</b>	19V DC	<b>Adapter</b>	100-240V, 50-60Hz / 19V DC
<b>Accessory</b>			
<b>Accessory</b>	Adapter and Power Cord Capacitive Stylus Standard Battery	<b>Optional Accessory</b>	Desk Dock (Optional) Vehicle Dock (Optional) Vehicle Cradle (Optional) Vehicle Charger (Optional) High Capacity Battery (Optional) Hand Strap (Optional) Shoulder Strap (Optional) Carry Bag (Optional)
<b>Barcode Scanner</b>			
<b>Barcode Scanner</b>	1D/2D barcode reader (Optional)		

**DIMENSIONS** UNIT:MM

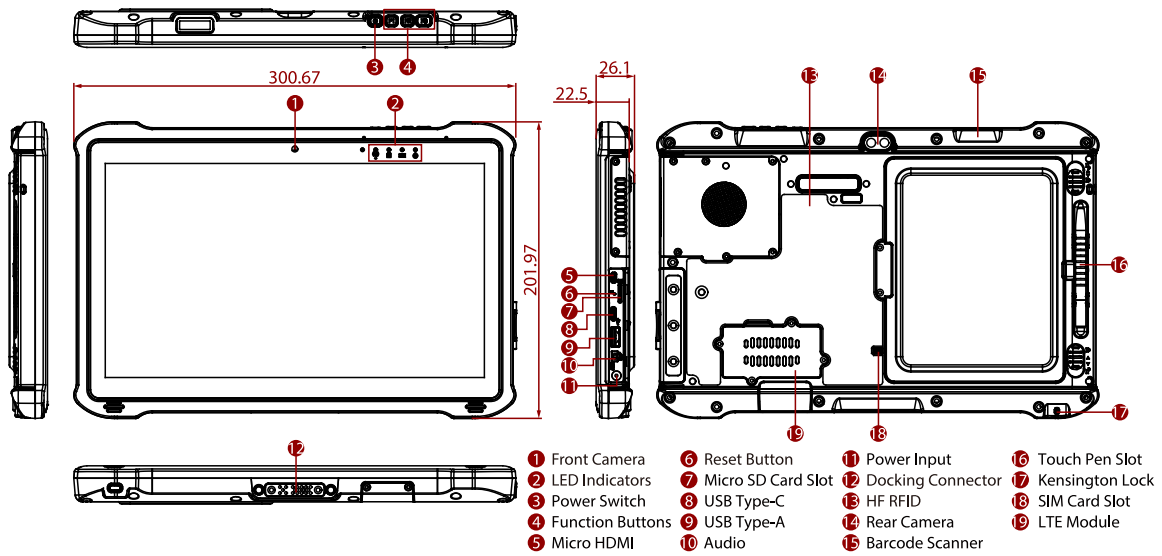

## NOTE

1. This is a simplified drawing and some components are not marked in detail.
2. Please contact our sales representative if you need further product information.
3. All specifications are subject to change without prior notice.
4. The product shown in this datasheet is a standard model. For diagrams that contain customized or optional I/O, please contact the Winmate Sales Team for more information.