

# M140TGT

## 14" Intel® Core™ i5-1135G7 Industrial Rugged Tablet Integrated Smart Card Reader



### KEY FEATURES

- 11th Gen. Intel® Processor Family – Tiger Lake Processor industrial rugged tablet
- 14-inch tablet, 1920 x 1080 wide viewing angle LED Panel
- Optical bonding and Antiglare technology for sunlight readability
- IP65 water and dust proof with MIL-STD-810H rugged housing
- Hot-swappable battery for wholodaywork
- Integrated Smart Card Reader



### OVERVIEW



#### See the data with less scrolling

M140TGT features a bigger screen with optical bonding technology and an anti glare coating, making the display readable even under sunlight. It supports rain and glove touch capability, offering visibility and productivity in hostile environments and situations.



#### Temperature tolerance

The M140TGT industrial mobile PC can operate in temperatures ranging from -20 to 60 degrees Celsius (when charging) or -10 to 50 degrees Celsius (on battery). It offers the flexibility of use for a wide range of industrial sectors.



#### Always ON industrial mobile PC

In a world where industrial mobile pc needs to work 24/7/365, power-up continuity is essential. The M140TGT has an internal battery that ensures a hot swap capability to support the never power-down industrial mobile PC, making it ideal when the device is pooled between workers or required across multiple work shifts.



#### Use it at ease anywhere and every time

The M140TGT's 14inch tablet comes with an optional kickstand/hard handle, and mounting choices make it very easy to carry. Rest assured that the device can withstand the impact, shock, vibration, liquid spills, and dust. The M140TGT industrial mobile pc has been independently tested and meets the IP65 rating and MIL-STD-810H standard.



#### Always in touch everywhere

M140TGT features an innovative docking connector, extensive connectivity possibilities, and many interfaces. Wireless LAN, BT, and optional cellular communications networks 4G/LTE to allow data to be exchanged in real-time.

### SPECIFICATIONS

Display			
Bonding	Optical Bonding for Sunlight Viewability	Resolution	1920x1080
Size	14.0 inches	Contrast Ratio	800:1

<b>Panel Brightness</b>	700.0 nits	<b>View Angles</b>	85,85,85,85
<b>Type</b>	Projected Capacitive Multi Touch		
<b>System Specification</b>			
<b>Processor</b>	Intel Core i5-1135G7 2.4GHz (up to 4.2GHz)	<b>Memory</b>	8GB DDR4 SDRAM 16GB DDR4 SDRAM (Optional) 32GB DDR4 SDRAM (Optional)
<b>Storage</b>	256GB SSD Additional storage available with micro SDXC card slot 512GB SSD (Optional) 1TB SSD (Optional) 2TB SSD (Optional)	<b>Security</b>	Trusted Platform Module (TPM) 2.0 Kensington Lock
<b>Operating System</b>	Windows 10 IoT Enterprise LTSC (64 bit) Windows 11 IoT Enterprise LTSC (64 bit) (Optional)	<b>WLAN</b>	Support
<b>BT</b>	Support	<b>WWAN</b>	4G LTE (Optional) 5G (Optional)
<b>GNSS</b>	GPS, GLONASS (Optional)	<b>RFID</b>	HF RFID reader 13.56 MHz (Optional)
<b>Sensors</b>	Light sensor/ G-sensor / Gyro	<b>Smart Card Reader</b>	Built-in Smart Card Reader, Comply with ISO7816-1.2.3 T=1 and T=Ø protocol
<b>Camera</b>			
<b>Front Camera</b>	2MP Front Camera	<b>Rear Camera</b>	8MP Rear Camera with auto-focus and LED light
<b>Mechanical</b>			
<b>Dimension</b>	341.91 x 224.67 x 25.4 mm	<b>Weight</b>	1.75 kg
<b>Cooling System</b>	Fan Design		
<b>IO Ports</b>			
<b>USB Port</b>	2 x USB 3.0 (Type A), 1 x USB 3.0 (Type-C support Power Delivery 20V In)	<b>SD Card Slot</b>	1 x Micro SDXC slot
<b>SIM Card Slot</b>	1 x Nano SIM card slot	<b>Video</b>	1 x Micro HDMI (Optional)
<b>Audio</b>	1 x Audio combo 3.5mm audio combo jack Dual Digital Mic With Noise Cancellation Dual Speaker	<b>LAN</b>	1 x RJ45-10/100/1000 GigaLAN port
<b>Indicator</b>	4x LED Indicator for Power, Battery, HDD, RF status	<b>Docking Connector</b>	1 x 19-pin docking connector
<b>Environment</b>			
<b>Operating Humidity</b>	10% to 90% RH, non-condensing	<b>Operating Temperature</b>	-20°C to 60°C
<b>Storage Temperature</b>	-30°C to 70°C (-22°F to 158°F)	<b>Shock</b>	MIL-STD-810H Method 516.8 Procedure I
<b>Vibration</b>	MIL-STD-810H Method 514.8 Procedure I	<b>IP rating</b>	IP65
<b>Drop</b>	MIL-STD-810H Method 516.8, 4 ft		
<b>Certification</b>			
<b>Certification</b>	CE, FCC		
<b>Security Function</b>			
<b>SOTI MobiControl</b>	SOTI MobiControl Compliance	<b>Kensington Lock</b>	Kensington Lock Support
<b>Control</b>			
<b>Button</b>	1 x Power, 3 x function keys		
<b>Power</b>			
<b>Battery</b>	Internal Battery: 10.8V typ. 2400 mAh Li-Ion Battery Hot-swappable 11.4V, typ. 3500 mAh Li-Ion Re-chargeable Battery (3S1P)	<b>Power Rating</b>	19V DC
<b>Adapter</b>	100-240V, 50-60Hz / 19V DC		
<b>Accessory</b>			
<b>Accessory</b>	Adapter and Power Cord Standard Battery Capacitive Stylus	<b>Optional Accessory</b>	Kickstand (Optional) Vehicle Charger (Optional) Battery Charger (Optional) Desk Dock (Optional) Carry Bag (Optional)

**DIMENSIONS** UNIT:MM

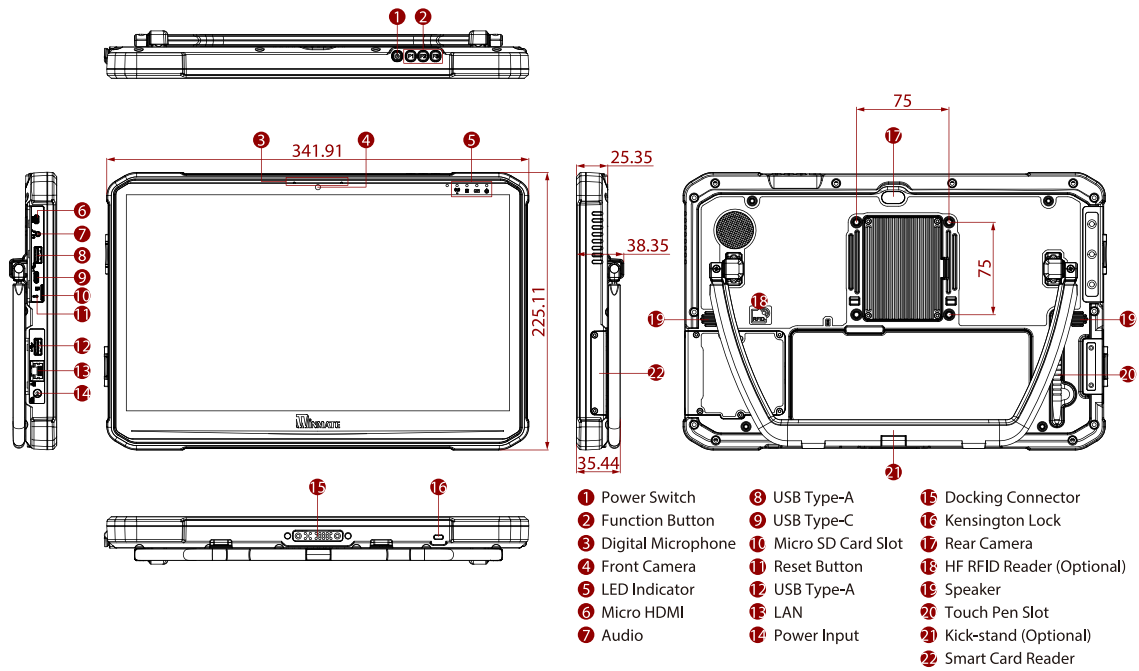

**NOTE**

1. This is a simplified drawing and some components are not marked in detail.
2. Please contact our sales representative if you need further product information.
3. All specifications are subject to change without prior notice.
4. The product shown in this datasheet is a standard model. For diagrams that contain customized or optional I/O, please contact the Winmate Sales Team for more information.