

M900EKN

8" Windows Rugged Tablet with Intel® Celeron® N6211



KEY FEATURES

- Intel Celeron N6211 Elkart Lake Processor rugged tablet PC
- 8" 1280x 800 IPS LED panel with direct optical bonding
- Integrated GigaLAN Port
- USB 3.0 type A, USB 3.0 type C connectors
- Sunlight readable with antiglare solution
- Projected capacitive (PCAP) multitouch
- IP65 waterproof and dustproof



OVERVIEW



Superior Display with WXGA (1280 X 800) Resolution

The Winmate M900EKN Rugged Tablet with an 8-inch WXGA (1280 x 800) screen and optical bonding, delivering exceptional image quality and enhanced outdoor visibility, even in bright sunlight with its 800 nits brightness level. Additionally, it offers increased durability and vivid visuals in various conditions.



Boost Connectivity with Integrated GigaLAN Port

With its RJ45 GigaLAN port, the M900EKN Rugged Tablet offers lightning-fast data and image transfers with speeds ranging from 10 to 1000 Mbps, making it perfect for factory automation and AIoT applications. This enhances productivity by reducing latency and improving response times, ensuring swift and efficient connectivity for seamless task support.



Equipped with Versatile Connectivity Options

The Winmate M900EKN Rugged Tablet offers both USB 3.0 Type A and Type C connectors for flexible connectivity, enhancing productivity across diverse industries and applications.



Designed for Durability and Mobility with IP65 Rating

The IP65 rating of the Winmate M900EKN Rugged Tablet ensures dependable performance in challenging conditions, offering waterproof and dustproof features for adaptable application in diverse industries.

SPECIFICATIONS

Display		Bonding	
Type	Projected Capacitive Multi Touch	Optical Bonding	Optical Bonding for Sunlight Viewability
Resolution	1280x800	Size	8.0 inches
Contrast Ratio	1500:1	Panel Brightness	800.0 nits
View Angles	80,80,80,80		
System Specification			
Processor	Intel Celeron N6211 1.2 GHz (turbo boost up to 2.60 GHz) Intel Pentium N6415 1.2 GHz (turbo boost up to 3.00 GHz) (Optional)	Memory	4GB LPDDR4 8GB LPDDR4 (Optional)
Storage	128GB SSD Additional storage available with micro SDXC card slot	Security	Trusted Platform Module (TPM) 2.0

Operating System	256GB SSD (Optional) 512GB SSD (Optional) Windows 10 IoT Enterprise LTSC (64 bit) Windows 11 IoT Enterprise LTSC (64 bit) (Optional)	WLAN	Support
BT	Support	WWAN	4G LTE (Optional)
GNSS	GPS, GLONASS	RFID	Mutually Exclusive with Barcode Reader HF RFID Reader 13.56 MHz (Optional) LF RFID Reader 125 KHz (Optional)
Sensors	Light sensor/ G-sensor / Gyro	Smart Card Reader	Smart Card Reader Comply with ISO7816-1.2.3 T=1 and T=Ø protocol (Optional)

Camera			
Front Camera	2MP Front Camera	Rear Camera	8MP Rear Camera with Autofocus and LED Light

Mechanical			
Dimension	225 x 148 x 20.5 mm (10 x 7.76 x 0.8 inches)	Weight	0.9 kg with battery
Cooling System	Fanless Design		

IO Ports			
USB Port	1 x USB 3.0 (Type A), 1 x USB 3.0 (Type C)	SD Card Slot	1 x Micro SDXC Slot
SIM Card Slot	1 x Micro SIM card slot	Audio	1 x Audio combo 3.5mm audio combo jack Dual Digital Mic With Noise Cancellation Dual Speaker
LAN	1 x RJ45-10/100/1000 GigaLAN port	Indicator	4x LED Indicator for Power, Battery, HDD, RF status
Docking Connector	1 x 19-pin docking connector		

Environment			
Operating Humidity	10% to 90% RH, non-condensing	Operating Temperature	-20°C to 60°C
Storage Temperature	-30°C to 70°C (-22°F to 158°F)	Shock	MIL-STD-810H Method 516.8 Procedure I
Vibration	MIL-STD-810H Method 514.8 Procedure I	IP rating	IP65
Drop	MIL-STD-810H Method 516.8, 5 ft		

Certification			
Certification	CE, FCC		

Security Function			
SOTI MobiControl	SOTI MobiControl Compliance		

Control			
Button	1 x Power, 1 x menu, 3 x Programmable Function Keys		

Power			
Battery	7.6V, typ. 4200 mAh Li Polymer Battery (2S2P)	Battery Operating Time	Standard. Battery: 6 hours
Power Rating	19V DC	Adapter	100-240V, 50-60Hz / 19V DC

Accessory			
Accessory	Adapter and Power Cord Standard Battery Pack	Optional Accessory	Desk Dock (Optional) Vehicle Dock (Optional) USB-A Cable (Optional) Battery Charger (Optional) Vehicle Charger (Optional) Hand Strap (Optional) Vehicle Cradle (Optional) LAN Cable (Optional) Capacitive Stylus (Optional)

Barcode Scanner			
Barcode Scanner	1D/2D barcode reader (Optional)		

DIMENSIONS UNIT:MM

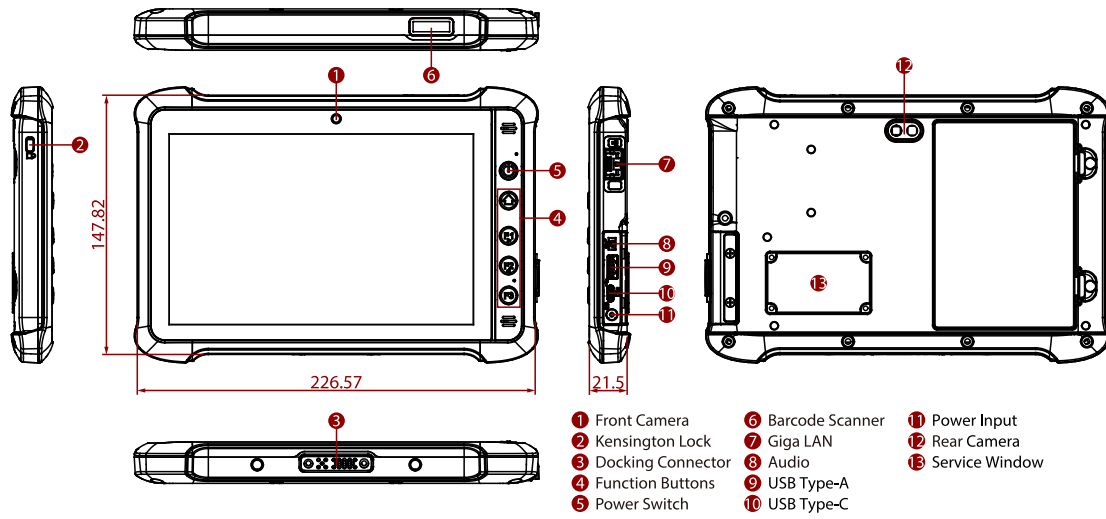

NOTE

- 1. This is a simplified drawing and some components are not marked in detail.
- 2. Please contact our sales representative if you need further product information.
- 3. All specifications are subject to change without prior notice.
- 4. The product shown in this datasheet is a standard model. For diagrams that contain customized or optional I/O, please contact the Winmate Sales Team for more information.