

FlexTwin SuperServer SYS-222FT-HEA-ALC

2U 4-Node FlexTwin™ with advanced liquid cooling (complete rack and onsite service are required)



Key Applications

Oil & Gas, Scientific Research, High Performance Computing (HPC), Research Lab,

Key Features

- Four **hot-pluggable** systems (nodes) in a 2U form factor. Each node supports the following;
- Dual Intel® Xeon® 6900 Series Processors with P-cores up to 500W with Advanced liquid cooling (Up to 95% heat capture);
- Up to 24 DIMMs supporting up to 6TB 6400MT/s DDR5 RDIMM or 3TB 8800MT/s DDR5 MRDIMM;
- Flexible networking with up to 1 OCP 3.0 compatible AIOM slots;
- Optional 1 PCIe 5.0 x16 FHHL slot + Default 1 PCIe 5.0 x16 LP slot;
- Optional 2 E1.S Slots + Optional 2 M.2 NVME drive Slots;
- 4 Redundant Up to 3200W Titanium Level Power Supplies;



Form Factor	2U Rackmount Enclosure: 449 x 88 x 916.6mm (17.67" x 3.46" x 36.08") Package: 701 x 293 x 1286mm (27.6" x 11.54" x 50.63")
Processor	Dual Socket BR (LGA-7529) Intel® Xeon® 6900 series processors with P-cores Up to 128C/256T; Up to 504MB Cache per CPU
System Memory	Slot Count: 24 DIMM slots Max Memory (1DPC): Up to 6TB 6400MT/s ECC DDR5 RDIMM Max Memory (1DPC): Up to 3TB 8800MT/s ECC DDR5 MRDIMM
Drive Bays Configuration	Option A: Total 2 bays <ul style="list-style-type: none"> • 2 front hot-swap E1.S NVMe* drive bays (*NVMe support may require additional storage controller and/or cables, please see the optional parts list for details) M.2: 2 M.2 PCIe 5.0 x4 NVMe slots (M-key 22110; optional configuration)
Expansion Slots	PCI-Express (PCIe) Configuration: Default <ul style="list-style-type: none"> • 1 PCIe 5.0 x16 LP slot • 1 PCIe 5.0 x16 AIOM slot (OCP 3.0 compatible) Option A* <ul style="list-style-type: none"> • 1 PCIe 5.0 x16 LP slot • 1 PCIe 5.0 x16 AIOM slot (OCP 3.0 compatible) • 1 PCIe 5.0 x16 FHHL slot M.2: 2 M.2 NVMe slots (M-key 22110(default); optional configuration)
On-Board Devices	NVMe: NVMe; RAID 0/1/5/10 support(Intel® VROC RAID key required) Chipset: System on Chip Network Connectivity: Via AIOM
Input / Output	LAN: 1 RJ45 1 GbE Dedicated BMC LAN port USB: 2 USB 2.0 Type-A ports(front) Video: 1 VGA port(Front)

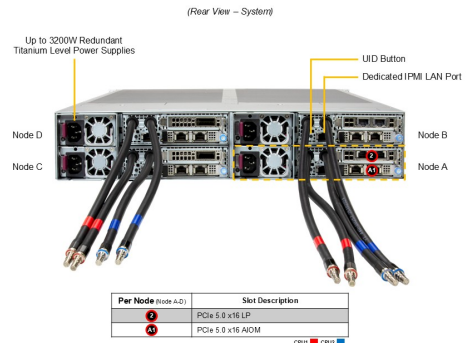
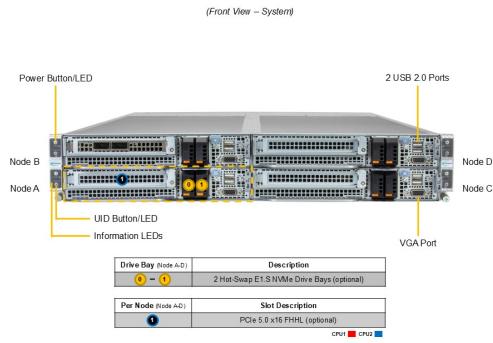

System Cooling	Fans: Up to 16x 31K RPM Counter Rotating 40x40x56mm Fan(s) Air Shroud: 4 Air Shrouds Liquid Cooling: Direct to Chip (D2C) Cold Plate
Power Supply	4x 3200W Redundant (2 + 2) Titanium Level (96%) power supplies
System BIOS	BIOS Type: AMI 64MB SPI Flash
Management	Supermicro Server Manager (SSM); Super Diagnostics Offline (SDO); Supermicro Thin-Agent Service (TAS); SuperServer Automation Assistant (SAA) New!
PC Health Monitoring	CPU: Monitors for CPU Cores, Chipset Voltages, Memory. FAN: Fans with tachometer monitoring Pulse Width Modulated (PWM) fan connectors Status monitor for speed control Temperature: Monitoring for CPU and chassis environment
Dimensions and Weight	Weight: Gross Weight: 148.2 lbs (67.28 kg) Net Weight: 124.2 lbs (56.39 kg) Available Color: Silver
Operating Environment	RoHS Compliant Operating Temperature: 10°C to 35°C (50°F to 95°F) Non-operating Temperature: -30°C to 60°C (-22°F to 140°F) Operating Relative Humidity: 8% to 80% (non-condensing) Non-operating Relative Humidity: 8% to 90% (non-condensing)
Motherboard	Super X14DBT-FLAP
Chassis	CSE-F214EC-000NP