

# FM12Q

## 12.1inch Android Car-mounted Computer with Qualcomm Snapdragon™ 660



### KEY FEATURES

- Qualcomm Snapdragon™ 660 octacore, 2.2 GHz CPU
- 12.1" 1024 x 768 Panel with PCAP Touch, Android car mounted computer
- Field replaceable front panel to reduce service costs
- IP65 waterproof and dustproof vehicle mounted computer
- Wide range -30°C to 50°C operating temperature



### OVERVIEW



#### Vibration and shock-proof design ensure reliable performance

When it comes to industrial usage, Winmate FM12Q that is rugged enough to survive harsh environments is a must. Its solid enclosure proves the FM12Q's durability with MIL-STD-810H certification and IP65 rating.

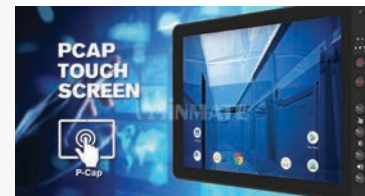

#### PCAP Touch Screen

The FM12Q features a compact panel with a PCAP touch screen. Resistant to dirt, debris, and highly sensitive touch commands make you enjoy every touch and convenience of using the device.



#### High-Performance CPU

To support the next generation of IoT edge devices, FM12Q has developed a new line of processors enhanced for IoT—Qualcomm® Snapdragon™ 660 Series processors. These processors build on new levels of CPU, and graphics performances with integrated IoT features, real-time performance, manageability, security, and functional safety.

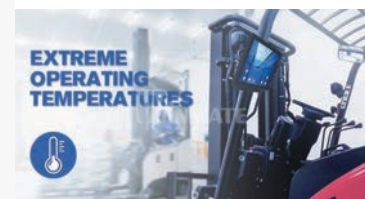

#### Reliable computing under extreme operating temperatures

Low-power components of industrial computers prevent overheating and are less likely to achieve high temperatures in the first place.

### SPECIFICATIONS

Display		Touch Mode	
Type	Projected Capacitive Multi Touch	Support Hand, Stylus, Glove Mode	
Resolution	1024x768	Size	12.1 inches
Contrast Ratio	1000:1	Panel Brightness	400 nits 800 nits(Optional)
View Angles	89,89,89,89		
System Specification			
Processor	Qualcomm® Snapdragon™ 660 (Octa-Core 2.2 GHz)	Memory	3GB
Storage	32GB	Operating System	Android 9.0
WLAN	Support	BT	Support
WWAN	4G/LTE (Optional)	GNSS	GPS/GLONASS

<b>Sensors</b>	G-Sensor, Temp. Sensor		
<b>Camera</b>			
<b>Front Camera</b>	2MP Camera		
<b>Mechanical</b>			
<b>Dimension</b>	Tablet: 307 x 225 x 41 mm Docking: 202 x 245 x 52 mm	<b>Weight</b>	Tablet 1.7 kg Docking 1.6 kg
<b>Mounting</b>	RAM mount/ VESA mount	<b>Cooling System</b>	Fanless Design
<b>Docking Housing</b>	Aluminum Alloy Housing		
<b>IO Ports</b>			
<b>USB Port</b>	1 x USB 3.0 Type C (OTG)(Tablet) 1 x DB9 Connector for 2 x USB 2.0 Port(Docking)	<b>Serial Port</b>	2 x COM Port(Docking)
<b>SD Card Slot</b>	1 x Micro SD Card Slot(Tablet)	<b>SIM Card Slot</b>	1 x Dual-Nano SIM Card Slot(Tablet)
<b>Audio</b>	2 x Speaker(Docking) 1 x CANBus or 1 x Audio(Docking)	<b>LAN</b>	1 x Gigabit LAN port(Docking)
<b>Indicator</b>	3 x LED Indicator (WLAN, UPS battery, Heater)	<b>Docking Connector</b>	SMA Connector(female) for external antenna WLAN SMA Connector(female) for external antenna GPS (Optional) SMA Connector(female) for external antenna WWAN (Optional)
<b>Environment</b>			
<b>Operating Humidity</b>	5% to 95% RH, Non-Condensing	<b>Operating Temperature</b>	-30°C to 60°C
<b>Storage Temperature</b>	-30°C to 60°C	<b>Shock</b>	MIL-STD-810H Method 516.8 Procedure I
<b>Vibration</b>	MIL-STD-810H Method 514.8 Procedure I	<b>IP rating</b>	IP65
<b>Impact</b>	Support EN62262 IK07 Rating	<b>ESD</b>	Compliant with EN 61000-4-2, Enhanced ESD to ±8kV Direct & ±12kV Air
<b>Certification</b>			
<b>Certification</b>	CE, FCC		
<b>Control</b>			
<b>Button</b>	1 x Power Button, 5 x Function Button (Programmable Function Key Configured by Winset)		
<b>Power</b>			
<b>Battery</b>	7.6V UPS Battery (2S1P) Minimum 30 minutes	<b>Power Rating</b>	Docking: 10V-60V with ignition control  Tablet: 12V DC In
<b>Security Function</b>			
<b>SOTI MobiControl</b>	SOTI MobiControl Compliance		
<b>Accessory</b>			
<b>Accessory</b>	5M Power Cable with Fuse Kit 0.3M USB Cable 0.15M Power Converter Cable DC Jack Power Cable 84W Adapter with power cable Cable Clamp Kit Wi-Fi Antenna x 2 Quick Start Guide External Antenna Fixing Bracket Dock + Latch Locking Key Stylus Kit + Screw	<b>Optional Accessory</b>	1.8M RS232 Cable 0.3M Audio Cable 1.8M CAN BUS Cable 1.8M CAN BUS Open Wire Cable 2M IP65 LAN Cable GPS & LTE 2M Combo Antenna(VM240) GPS & LTE 5M Combo Antenna (VM9C) Magnetic Combo Antenna (VM10S) WWAN Antenna HDMI Adapter

**DIMENSIONS** UNIT:MM

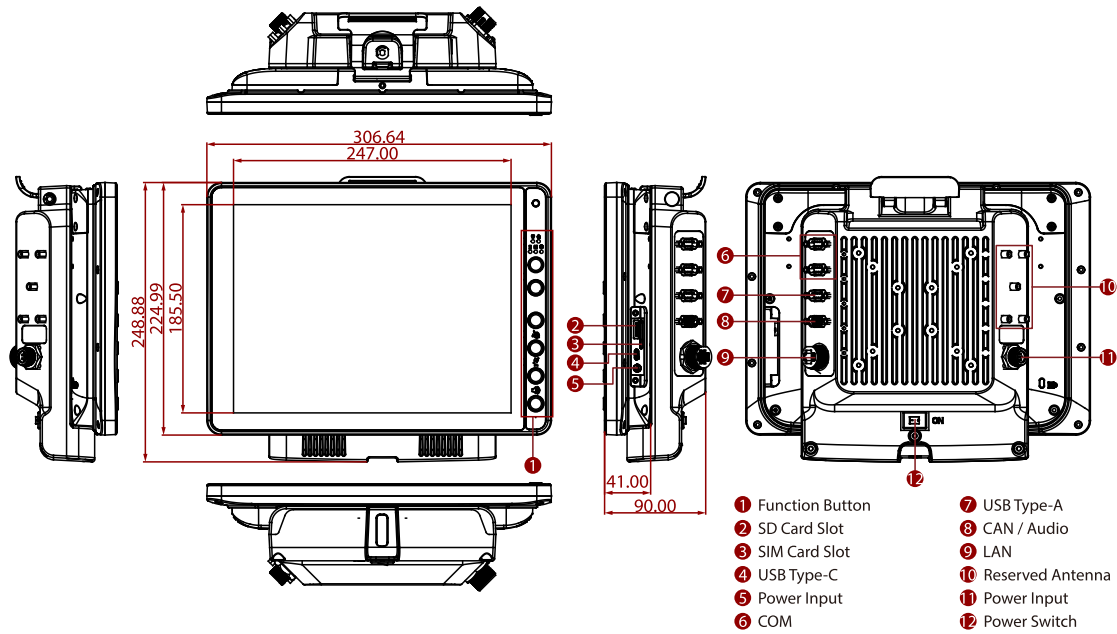

**NOTE**

1. Total usable memory will be less dependent upon actual system configuration.
2. CANBus and audio are mutually exclusive.
3. The heater is a customized feature available by request.
4. SOTI is available upon request.
5. Length measurements do not include protrusions. Weight varies with options.
6. Measured at dimming LCD brightness. Varies depending on the usage conditions, or when an external device is attached.
7. Accessories may vary depending on your configuration.
8. Two Wi-Fi antennas are included in the standard package.
9. The product shown in this datasheet is a standard model. For diagrams that contain customized or optional I/O, please contact the Winmate Sales Team for more information.
10. Please order one bracket for one antenna. For example, if you plan to use two antennas, please order two brackets.
11. Notice that only one antenna is included in the package. If you plan to use the WWAN function please order two WWAN antennas.
12. This is a simplified drawing and some components are not marked in detail.
13. COM port can supply 5V power via the 9th pin.