

M700DQ8-EX

7-inch Qualcomm® Snapdragon™ 660, ATEX Rugged Android PDA



KEY FEATURES

- Qualcomm® Snapdragon™ 660, Octa-core up to 2.2 GHz , ATEX rugged android PDA
- 7 inch android tablet, 1280 x 720 TFT Panel with direct optical bonding
- Supports Android 9.0 OS, Sunlight readable android tablet
- IP65 waterproof and dustproof
- Rated for extreme temperature use
- ATEX Zone 2 application certification



OVERVIEW



High-Performance Qualcomm®; Snapdragon™; 660 Processor & 7 inch tablet

This handheld rugged tablet is powered by a Qualcomm®; Snapdragon™; 660 Processor, delivering faster response times and enhanced performance. Additionally, the intuitive Android interface significantly boosts productivity.



Real-Time Data and Wireless Connectivity

Real-time access to accurate information is essential for mobile workers. With features including GPS/AGPS/GLONASS, WLAN, Bluetooth, and optional 4G LTE, workers can share files and communicate anytime, anywhere. The built-in 13.0 MP rear camera allows for instant capture of photos, videos, and documents, while the 8.0 MP front camera is ideal for self-recording and video calls.



Brilliant " Sunlight Readable Display

The 7-inch Android tablet features a sunlight-readable 1280 x 720 TFT LCD screen, crafted with direct optical bonding technology for vibrant, true-to-life colors. It also supports automatic screen rotation for enhanced ease of use.



Ultimate Productivity for Field Work

Data collection has never been simpler, thanks to a variety of optional tools designed to assist mobile workers. The optional NFC reader provides default read and write functions, while an additional 1D/2D barcode scanner can be integrated for expanded data collection capabilities.



Accessories Tailored for Your Application

This tablet is ideal for in-vehicle applications when paired with its docking station and adapter. Easily transition from an in-vehicle solution to a handheld device, allowing you to store it in a carry bag for complete mobility.

SPECIFICATIONS

Display			
Resolution	1280x720	Size	7.0 inches
Contrast Ratio	800:1	Panel Brightness	650 nits

View Angles	80,80,80,80	Type	Projected Capacitive Multi Touch
Touch Mode	Support Hand / Gloves and Rain Mode	Bonding	Optical Bonding for Sunlight Viewability
System Specification			
Processor	Qualcomm® Snapdragon™ 660 (Octa-Core 2.2 GHz)	Memory	3GB
Storage	32GB	Operating System	Android 9.0
WLAN	Support	BT	Support
WWAN	4G/LTE (Optional)	GNSS	GPS/GLONASS
RFID	NFC (Read / Write, Peer to Peer mode) (Optional)	Sensors	Ambient Light Sensor, E-Compass, Gyro, Acceleration Sensors
Camera			
Front Camera	8MP Camera	Rear Camera	13MP Camera with LED Auxiliary Light (Auto Focus)
Mechanical			
Dimension	212.4 x 132.8 x 19 mm	Weight	550g
IO Ports			
USB Port	1 x USB 3.0 Type C OTG	SD Card Slot	1 x Micro SD Card Slot
SIM Card Slot	1 x Micro SIM Card Slot	Audio	1 x Audio Combo connector (Mic in and Line Out) 2 x Built-in Mic 1 x Speaker 1 x Earphone
Indicator	2 x LED Indicators (Power, Battery)	Docking Connector	1 x Docking Connector
Environment			
Operating Humidity	5% to 95% RH, Non-Condensing	Operating Temperature	-10°C to 50°C (Battery mode) -20°C to 60°C (Charging mode) Please avoid charging in hazardous locations.
Storage Temperature	-30°C to 70°C	Shock	MIL-STD-810G Method 516.6 Procedure I
Vibration	MIL-STD-810G Method 514.6 Procedure I	IP rating	IP65
Drop	MIL-STD-810G Method 516.6, 5 ft		
Certification			
Certification	CE, FCC ATEX Zone 2 EX II 3 G Ex ic IIC Gc		
Control			
Button	1 x Volume + , 1 x Volume - , 1 x Power Button, 1 x Home Button, 1 x Menu Button, 1 x Return Button, 1 x Trigger Button		
Power			
Battery	3.7V 5300mAh	Battery Operating Time	20Hr
Power Rating	DC 5V	Adapter	Input: 100V-240V AC Output: DC 5V 3A
Security Function			
SOTI MobiControl	SOTI MobiControl Compliance		
Accessory			
Accessory	Universal Adapter x1 Battery x1 USB Type-C Cable x1	Optional Accessory	Battery Charging Dock Vehicle Dock (Charging + Connectors) Vehicle Dock (Charging Only) Desk Dock Hand Strap Micro SD Card Capacitive Touch Stylus Vehicle Adapter HDMI Adapter
Barcode Scanner			

DIMENSIONS UNIT:MM

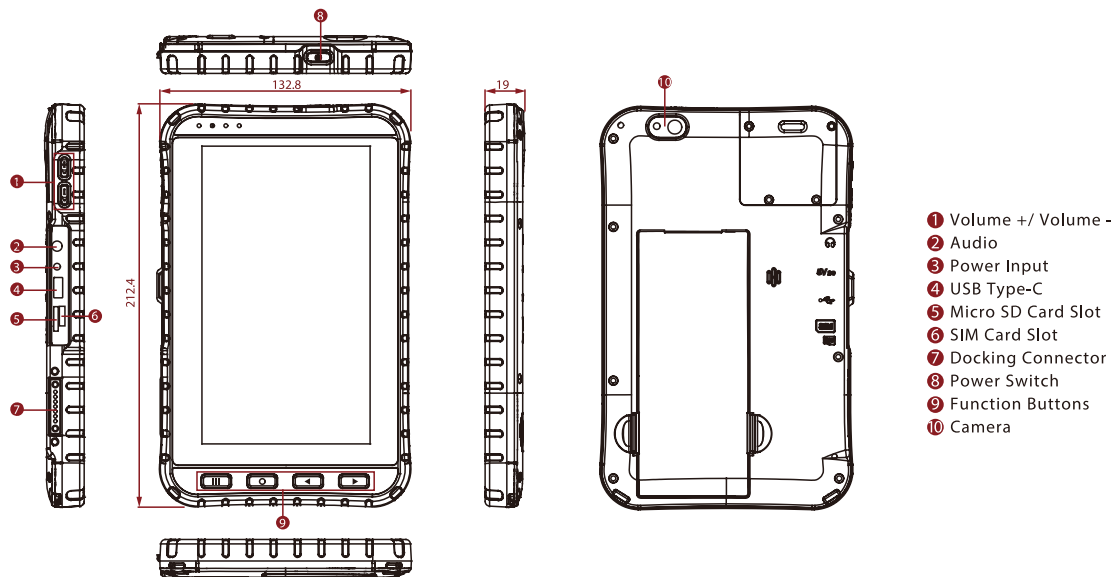

- ❶ Volume +/- Volume -
- ❷ Audio
- ❸ Power Input
- ❹ USB Type-C
- ❺ Micro SD Card Slot
- ❻ SIM Card Slot
- ❼ Docking Connector
- ❽ Power Switch
- ❾ Function Buttons
- ❿ Camera

NOTE

1. Total usable memory will be less dependent upon actual system configuration.
2. SOTI is available upon request.
3. Length measurements do not include protrusions.
4. The drop test with a high-capacity battery must come with a hand strap.
5. Measured at dimming LCD brightness. Varies depending on the usage conditions, or when an external device is attached.
6. Accessories and integrated options may vary depending on your configuration.
7. This is a simplified drawing and some components are not marked in detail.
8. The product shown in this datasheet is a standard model. For diagrams that contain customized or optional I/O, please contact the Winmate Sales Team for more information.